

# **BRE 86**

## **DATA REPORT FOR THE VERTICAL-COMPONENT SEISMIC REFRACTION DATA OBTAINED DURING THE 1986 PASSCAL BASIN AND RANGE LITHOSPHERIC SEISMIC EXPERIMENT, NORTHERN NEVADA**

Submitted by

Dean Whitman & R. D. Catchings

1987

### **PASSCAL Data Report**



Distributed by

*Incorporated Research Institutions for Seismology  
Data Management Center  
1408 NE 45th Street  
2nd Floor  
Seattle, Washington 98105*

UNITED STATES DEPARTMENT OF THE INTERIOR  
GEOLOGICAL SURVEY

---

DATA REPORT FOR THE VERTICAL-COMPONENT SEISMIC REFRACTION DATA  
OBTAINED DURING THE 1986 PASSCAL BASIN AND RANGE LITHOSPHERIC  
SEISMIC EXPERIMENT, NORTHERN NEVADA

---



OPEN-FILE REPORT 87-415

**This report (map) is preliminary and has not been reviewed for conformity with U.S. Geological Survey editorial standards (and stratigraphic nomenclature). Any use of trade names is for descriptive purposes only and does not imply endorsement by the U.S.G.S.**

*Menlo Park, California*

*1988*

UNITED STATES DEPARTMENT OF THE INTERIOR  
GEOLOGICAL SURVEY

DATA REPORT FOR THE VERTICAL-COMPONENT SEISMIC REFRACTION DATA  
OBTAINED DURING THE 1986 PASSCAL BASIN AND RANGE LITHOSPHERIC  
SEISMIC EXPERIMENT, NORTHERN NEVADA

DEAN WHITMAN AND R. D. CATCHINGS<sup>1</sup>

OPEN-FILE REPORT 87-415

This report is preliminary and has not been reviewed for conformity with U.S. Geological Survey editorial standards and stratigraphic nomenclature. Any use of trade names is for descriptive purposes only and does not imply endorsement by the U.S.G.S.

<sup>1</sup>U.S.G.S. Menlo Park, California

1987

## Table of Contents

	Page
Introduction .....	1
Description of Survey .....	1
Instrumentation and Field Operations.....	3
Data Reduction.....	4
Archive Tape.....	5
Acknowledgements .....	5
References Cited.....	5
Appendix A: Field Data Sheets and Tape Grade Scale .....	39
Appendix B: Merged GEOS Data for Deployment 1 .....	66
Appendix C: Instrument Response of Seismic Cassette Recorders and GEOS .....	68
Appendix D: Archive Tape Data Format .....	71

## Figures

1. Index Map Showing Shotpoint and Recorder Locations.....	2
2. Schematic Diagram of Seismic Recorders .....	11
3. System Response Curve for Seismic Recorders .....	12
4. Record Section of Shot 1, Shotpoint 8 - Deployment 1 .....	13
5. Record Section of Shot 2, Shotpoint 10 - Deployment 1 .....	14
6. Record Section of Shot 3, Shotpoint 11 - Deployment 1 .....	15
7. Record Section of Shot 4, Shotpoint 1 - Deployment 1 .....	16
8. Record Section of Shot 5, Shotpoint 9 - Deployment 1 .....	17
9. Record Section of Shot 6, Shotpoint 8 - Deployment 1 .....	18
10. Record Section of Shot 7, Shotpoint 11 - Deployment 1 .....	19
11. Record Section of Shot 8, Shotpoint 4 - Deployment 1 .....	20
12. Record Section of Shot 9, Shotpoint 4 - Deployment 2 .....	21
13. Record Section of Shot 10, Shotpoint 5 - Deployment 2 .....	22
14. Record Section of Shot 11, Shotpoint 1 - Deployment 2 .....	23
15. Record Section of Shot 12, Shotpoint 3 - Deployment 2 .....	24
16. Record Section of Shot 13, Shotpoint 7 - Deployment 2 .....	25
17. Record Section of Shot 14, Shotpoint 12 (4a) - Deployment 2 ....	26
18. Record Section of Shot 15, Shotpoint 8 - Deployment 2 .....	27
19. Record Section of Shot 16, Shotpoint 13 (4b) - Deployment 2 ....	28
20. Record Section of Shot 17, Shotpoint 2 - Deployment 2 .....	29
21. Record Section of Shot 18, Shotpoint 7 - Deployment 3 .....	30
22. Record Section of Shot 19, Shotpoint 8 - Deployment 3 .....	31
23. Record Section of Shot 20, Shotpoint 14 (4c) - Deployment 3 ....	32
24. Record Section of Shot 21, Shotpoint 1 - Deployment 3 .....	33
25. Record Section of Shot 22, Shotpoint 15 (4d) - Deployment 3 ....	34
26. Record Section of Shot 23, Shotpoint 4 - Deployment 3 .....	35
27. Record Section of Shot 24, Shotpoint 3 - Deployment 3 .....	36
28. Record Section of Shot 25, Shotpoint 6 - Deployment 3 .....	37
29. Record Section of Shot 26, Shotpoint 5 - Deployment 3 .....	38

## Tables

1. Shot Locations and Times .....	6
2. Seismic Recorder Locations .....	8
Deployment 1 .....	8
Deployment 2 .....	9
Deployment 3 .....	10
C1. System Gain Parameters: Seismic Cassette Recorders and GEOS.....	69

In July, 1986, the United States Geological Survey (USGS) conducted a seismic refraction/reflection survey in northern Nevada as part of the Program for Array Seismic Studies of the Continental Lithosphere (PASSCAL) Basin and Range Lithospheric Seismic Experiment. The major purposes of the experiment were to investigate the uncertainties in the crustal and upper-mantle velocity structure (reviewed by Catchings, 1987), to investigate differences between the interpretations of previous wide-angle (Eaton, 1963) and vertical-incident (Klemperer and others, 1986) seismic studies, and to enhance existing reflection and refraction data in that region. Explosions fired on the nights of July 22, 25, and 29, were recorded by 120 vertical-component USGS seismic cassette recorders (SCR's), 40 three-component recorders, and a 396 channel seismic reflection array by participants from 17 universities and government institutions. This report is a compilation of the vertical-component seismic refraction data collected by the USGS during this survey.

### Description of the Survey

The survey consisted of a 200-km-long NE-SW trending strike profile and an intersecting 280-km-long NW-SE trending cross profile (Fig. 1). Seismic sources were generated by a total of 26 explosions, which were detonated in 20-cm diameter boreholes at depths ranging from 45 to 70 meters. Explosions were generated by 225 to 2700 kg of ammonium nitrate explosive. Shot times, locations, sizes are listed in Table 1. Seismic recorder sites, shown in map view on figure 1, are also listed by latitude and longitude on Table 2.

The vertical-component data from the NE-SW profile were recorded in one deployment (deployment 1), which extended from Winnemucca, Nevada to southeast of Fallon, Nevada. A total of 130 vertical-component recorder sites were occupied (locations 101-230, Table 2) with an average spacing of 1.5 km. For deployment 1, in-line shots were fired from shotpoints 4, 8, 9, 10, and 11. In addition, a fan shot was fired from shotpoint 1. Shotpoints 8 and 11 were each fired twice.

Vertical-component data from the NW-SE profile were recorded in two separate deployments (deployments 2 and 3; locations 301-412, 501-618, Table 2). The entire profile extends from near Gerlach, Nevada to the Monitor Range with seismic recorder spacing ranging from 0.9 to 1.4 km. The westernmost deployment, deployment 2, extended from shotpoint 1 (Gerlach) to shotpoint 4 (Buena Vista Valley) and consisted of six in-line shots (shotpoints 1, 2, 3, 4, 12 (4a), and 13 (4b)) over the recording array, two offset shots (shotpoints 5 and 7), and a fan shot (shotpoint 8). The easternmost deployment, deployment 3, extended from shotpoint 4 to shotpoint 7 (Monitor Valley) and also consisted of six in-line shots (shotpoints 4, 5, 6, 7, 14 (4c), and 15 (4d)) over the seismic array, two offset shots (shotpoints 1 and 3), and a fan shot (shotpoint 8).

Figure 1: Index map of the study area showing shotpoint and recorder locations. Stars denote shotpoint locations; small triangles denote recorder locations.

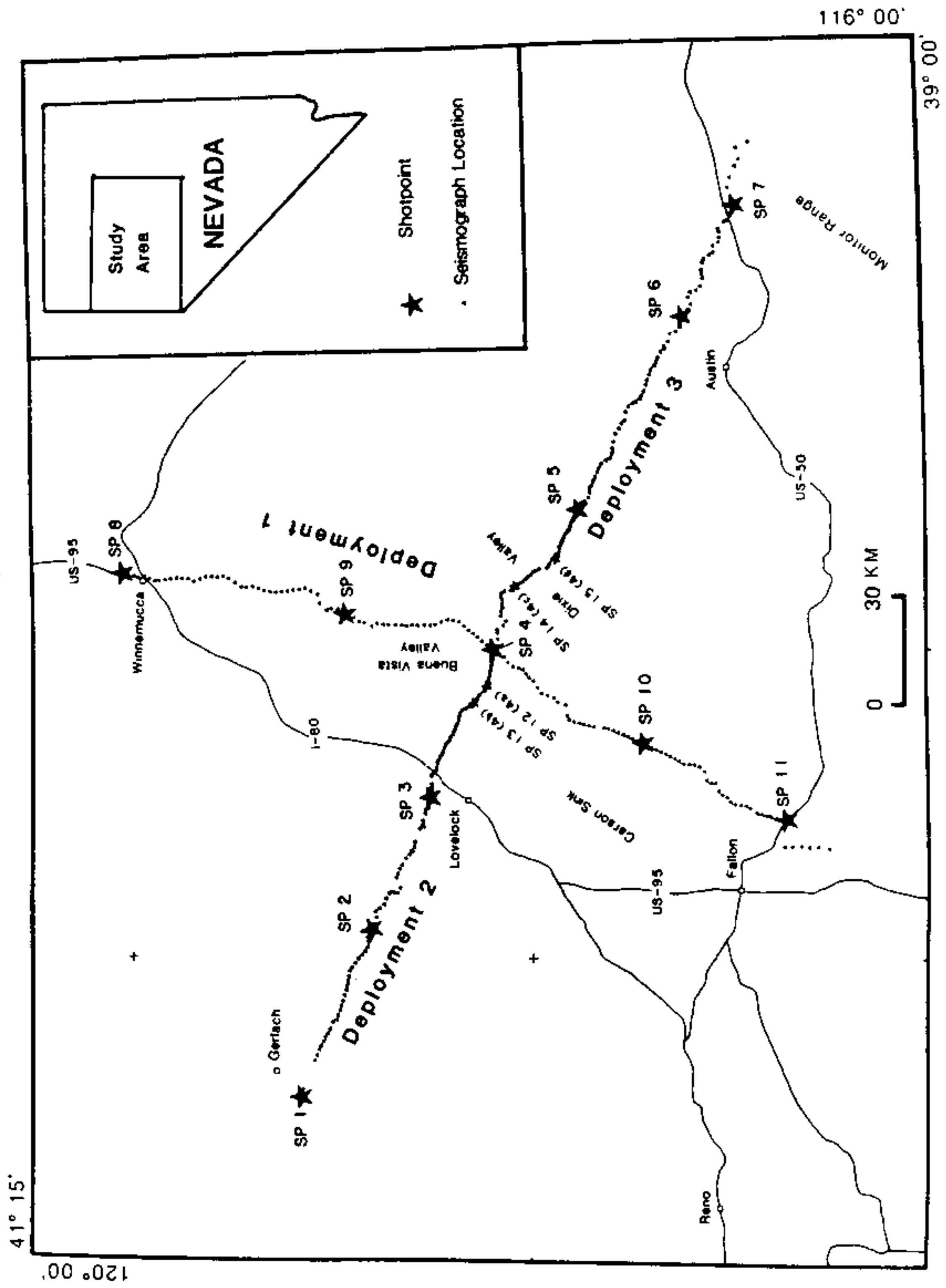

### Instrumentation and Field Operations

Prior to the data acquisition phase of the experiment, vertical-component recorder sites (Table 2) were surveyed using USGS (1:24000) orthophotographs and (1:24000 and 1:62500) topographic maps. During each deployment, station locations were resurveyed by the observer crew for accuracy. Combined errors in elevation and geographic locations are estimated to no more than +25 meters.

Explosive sources were detonated by automated shooting systems, described by Healy and others, 1982, on the night of each deployment. The blasting cap-break, WWVB time code, and IRIG E time code from a USGS master clock were recorded on a Kiowa™ paper strip chart recorder. Because the master clocks drift about 1 millisecond per week, they were synchronized in the field to National Bureau of Standards clocks with a Kinematics Truetime™ portable satellite receiver/clock, accurate to 1.5 milliseconds. Shot times were picked from the paper record to within an estimated accuracy of 2 milliseconds.

Prior to each set of shots, USGS observers deployed 120 SCR's (Healy and others 1982) and 20 3-component GEOS (General Earthquake Observation System) recorders (Borcherdt and others, 1985). Each SCR contained a 2-Hz vertical-component velocity transducer geophone, which was oriented and buried during deployment of the recorder. Output from the geophone was sent through three parallel amplifiers, each with an adjustable attenuation setting. The three amplified seismic signals, a fixed reference frequency, and an internally generated time code were recorded as a multiplexed signal in analog form on a 30-minute cassette tape (Fig. 2). Each SCR contained a USGS time code generator and memory board, which is programmable for up to ten separate recording times. Prior to each recording time, a pre-programmed microprocessor in the seismic recorder performed a geophone release test, an amplification check, and a calibration sequence consisting of a 10-Hz sine wave with amplitudes of 1, 10, 100, and 1000 microvolts RMS. The input signal results in a recording system with a displacement response peak of about 26 Hz and velocity response peak of about 6 Hz (Fig. 3; Dawson and Stauber, 1986).

Before each deployment, recording times were programmed into the SCR's, amplifier attenuations were set, and the SGR chronometer was set with a master reference clock. After the SGR's were retrieved, chronometer drifts were measured relative to the master clock.

### Data Reduction

Information pertaining to shot times, SCR locations, amplifier attenuation settings, chronometer drifts, and SCR performance was entered into a microcomputer and stored on a floppy disk. Chronometer drifts were calculated assuming a linear drift between the time the chronometer was set and the shot time. The analog seismic data were digitized for a total of 20 seconds at a sampling rate of 200 samples/second. Digitization began at time:  $T = \text{shot time} - T_{\min} + \text{distance}/6.0 \text{ km/s}$ .

A list of  $T_{\min}$  (in seconds) is given below for each shot.

Shot	$T_{\min}(\text{s})$	Shot	$T_{\min}(\text{s})$	Shot	$T_{\min}(\text{s})$
1	-2	9	-2	18	-2
2	-2	10	-3	19	-2
3	-3	11	-2	20	-2
4	-3	12	-6	21	-6
5	-3	13	-2	22	-2
6	-3	14	-2	23	-2
7	-3	15	-2	24	-3
8	0	16	-2	25	-2
		17	-2	26	-2

Amplifier calibrations for each recorder were digitized and data from the highest gain, non-clipped channel were selected. The digitized data were checked for errors in the timing, station location, and attenuation settings before a final version of the data was stored on 9-track magnetic tape. Information pertaining to instrument location, distance, azimuth, attenuation, and SCR performance for each shot is given in Appendix A.

For deployment 1, vertical-component GEOS data (Appendix B) were merged with the SCR data. Prior to merging, the GEOS data were filtered by a 50-Hz low pass filter and decimated to 200 samples/second, the sampling rate used for the SCR's. A complete presentation of the GEOS data for the PASSCAL experiment is given in a separate report (Dietel and Borchardt, 1987). A comparison of the amplitude response of the SCR data and the GEOS data is given in Appendix C.

### Record Sections

Record sections for each shot (Figures 4 through 29) are plotted with amplitudes normalized to a common value for each trace and at a reduction velocity of 6.0 km/s. Negative distances indicate recorder sites south of each shotpoint along the NE-SW profile and east of each shotpoint along the NW-SE profile. Traces for the fan shots are plotted at distances relative to shotpoint 11 for the NE-SW profile (shot 4), and shotpoint 1 for the NW-SE profile (shots 15 and 19).

### Archive Tape

Data included in this report are available on SEGY-formatted magnetic tapes (1600 BPI density; see Appendix D) from the following:

IRIS, Data Management Center  
 Incorporated Research Institutions for Seismology  
 1616 N. Ft. Myer Drive, Suite 1440  
 Arlington, Virginia 22209

### Acknowledgements

We wish to express our appreciation to H. Benz, P. Berge, R. Colburn, J. Cotton, E. Criley, C. Gilbert, L. Green, V. Heilweil, W. Kohler, S. Lewis, J. Luetgert, R. Luzitano, B. McClearn, C. McKissick, W. Mooney, J. Murphy, R. Ray, T. Reed, D. Reneau, J. Shemeta, J. Van Schaack, A. Walter, C. Watson, and J. Wilson for their assistance in data acquisition, processing, and/or administration.

### References cited

- Barry, K. M., Cravers, D. A., and Kneale, C. W., (1975), Recommended standards for digital tape formats: *Geophysics* 40, 344-352.
- Borcherdt, R. D., Fletcher, J. B., Jensen, E. G., Maxwell, G. L., VanSchaack, J. R., Warrick, R. E., Cranswick, E., Johnston, M. J. S., and McClearn, R., (1985), A General Earthquake-Observation System (GEOS), *Bull. Seismological Society of America*, 75, 1783-1825
- Catchings, R. D. (1987) *Crustal Structure of the Northwestern United States*, Ph.D. Thesis, Stanford University, Stanford, California, 185pp.
- Dawson, P. B., and Stauber, D. A., (1980), Data Report for a Three-dimensional High-resolution P-velocity Structural Investigation of Newberry Volcano, Oregon, using Seismic Tomography, U.S. Geological Survey Open-File Report USGS-OF-86-352, 45 pp. plus plates.
- Dietel, C., and Borcherdt, R. D., (1987), GEOS Data Summary for Active and Passive Seismic Experiments Conducted in Support of Northern Nevada Lithospheric Experiments - PASSCAL, U.S. Geological Survey Open-File Report USGS OF 87-326, 22 pp. plus tables and figures.
- Eaton, J. P., (1963), Crustal structure from San Francisco, California, to Eureka, Nevada, from seismic refraction measurements, *Journal of Geophysical Research*, 68, 5789-5806.
- Healy, J. H., Mooney, W. D., Blank, H. R., Gettings, M. E., Kohler, W. M., Lamson, R. J., and Leone, L. E., (1982), Saudi Arabian Seismic Deep-refraction Profile: Final Project Report, U.S. Geological Survey Open-File Report USGS-OF-02-37, 429 pp.
- Klemperer, S. L., Hauge, T. A., Hauser, E. C., Oliver, J. E., Potter, C. J., (1986), The Moho in the northern Basin and Range province, Nevada, along the COCORP 400N seismic-reflection transect, *Bull. Seismological Society of America*, 97, 603-611.

Table 1: Master Shot List. Includes the shot number, shotpoint number, date (calendar and Julian), shot time (GMT), latitude (degrees, minutes), longitude (degrees, minutes), charge size (lbs), and notes pertaining to each shot.

DEPLOYMENT 1 JULY 22, 1986

Shot Number	Shot Point	Date Shot Time	Latitude Longitude	Size (lbs)	Notes
1	8	JUL 22, 1986 204 5 0 0.016	41 1.1660 117 43.0850	3000	Winnemucca
2	10	JUL 22, 1986 204 5 4 0.009	39 43.3254 118 17.6982	2000	Carson Sink
3	11	JUL 22, 1986 204 5 6 0.010	39 21.6223 118 32.8763	3000	Fallon
4	1	JUL 22, 1986 204 5 8 0.006	40 34.9624 119 27.5166	3000	Gerlach (Far Shot)
5	9	JUL 23, 1986 204 7 0 0.006	40 27.9109 117 51.7158	2000	East Range
6	8	JUL 23, 1986 204 7 2 0.011	41 1.1660 117 43.0850	3000	Winnemucca
7	11	JUL 23, 1986 204 7 5 56.986	39 21.6223 118 32.8789	2200	Fallon
8	4	JUL 23, 1986 204 7 8 0.009	40 5.7737 117 59.4604	2000	Buena Vista Valley

## DEPLOYMENT 2 JULY 25, 1986

Shot Number	Shot Point	Date Shot Time	Latitude Longitude	Size (lbs)	Notes
9	4	JUL 25, 1986 207 5 0 0.010	40 5.7737 117 59.4604	3000	Buena Vista Valley
10	5	JUL 25, 1986 207 5 2 0.009	39 52.5652 117 31.8740	4000	Augusta Mtns. (Offset Shot)
11	1	JUL 25, 1986 207 5 4 0.130	40 34.9624 119 27.5166	3000	Gerlach
12	3	JUL 25, 1986 207 5 6 5.848	40 15.5601 118 28.4468	2000	Lovelock
13	7	JUL 25, 1986 207 5 8 0.012	39 28.2034 116 32.5405	6000	Monitor Range (Offset Shot)
14	12	JUL 26, 1986 207 7 0 0.008	40 6.8945 118 6.2925	600	Buena Vista Val. Shotpoint 4A
15	8	JUL 26, 1986 207 7 6 0.096	41 1.1660 117 43.0850	2000	Winnemucca (Fan shot)
16	13	JUL 26, 1986 207 9 0 0.010	40 8.8538 118 9.7485	500	Humboldt Range Shotpoint 4B
17	2	JUL 26, 1986 207 9 4 0.320	40 24.5386 118 54.6162	2000	Bluewing Mtns.

## DEPLOYMENT 3 JULY 29, 1986

Shot Number	Shot Point	Date Shot Time	Latitude Longitude	Size (lbs)	Notes
18	7	JUL 29, 1986 211 5 0 0.008	39 28.2034 116 32.5405	3000	Monitor Valley
19	8	JUL 29, 1986 211 5 2 0.012	41 1.1660 117 43.0850	1500	Winnemucca (Fan Shot)
20	14	JUL 29, 1986 211 5 4 0.012	40 2.4484 117 46.5786	500	Shotpoint 4C Dixie Valley
21	1	JUL 29, 1986 211 5 6 0.012	40 34.9624 119 27.5166	6000	Gerlach (Offset Shot)
22	15	JUL 29, 1986 211 5 8 0.011	39 56.2168 117 41.2944	500	Shotpoint 4D Dixie Valley
23	4	JUL 30, 1986 211 7 0 0.008	40 5.7737 117 59.4604	3000	Buena Vista Valley
24	3	JUL 30, 1986 211 7 2 0.012	40 15.5601 118 28.4468	4000	Lovelock (Offset Shot)
25	6	JUL 30, 1986 211 7 6 0.008	39 36.4334 116 54.4380	1000	Toiyabe Range
26	5	JUL 30, 1986 211 7 8 0.009	39 52.5652 117 31.8740	2000	Augusta Mtns.

Table 2: Seismic Recorder Locations. Includes location number, latitude, longitude, and elevation.

## Deployment 1

Location number	Latitude (deg,min,sec)	Longitude (deg,min,sec)	Elev (m)	Location number	Latitude (deg,min,sec)	Longitude (deg,min,sec)	Elev (m)	Location number	Latitude (deg,min,sec)	Longitude (deg,min,sec)	Elev (m)
101	41 1 7.7	117 43 6.2	1310	151	40 18 58.3	117 54 20.8	1258	201	39 41 54.0	118 18 31.6	1213
102	41 0 30.4	117 43 23.8	1310	152	40 18 7.7	117 54 11.7	1255	202	39 41 12.1	118 18 56.9	1203
103	40 59 40.3	117 43 42.6	1316	153	40 17 17.0	117 54 15.1	1255	203	39 40 30.1	118 19 23.0	1203
104	40 59 3.2	117 44 3.8	1316	154	40 16 18.6	117 54 12.4	1255	204	39 39 47.4	118 19 47.9	1203
105	40 58 8.3	117 43 49.1	1325	155	40 15 25.2	117 54 17.5	1249	205	39 39 6.6	118 20 18.2	1203
106	40 57 19.8	117 44 19.6	1325	156	40 14 39.3	117 54 10.3	1249	206	39 38 25.9	118 20 48.7	1203
107	40 56 32.3	117 44 48.1	1325	157	40 13 43.8	117 53 39.1	1267	207	39 37 45.5	118 21 19.5	1197
108	40 55 50.2	117 44 45.1	1341	158	40 12 47.0	117 53 13.2	1280	208	39 37 4.3	118 21 49.6	1197
109	40 54 58.2	117 44 38.2	1356	159	40 11 54.7	117 53 21.3	1280	209	39 36 17.0	118 22 0.3	1197
110	40 54 7.7	117 44 25.9	1371	160	40 11 2.1	117 53 38.0	1267	210	39 35 29.3	118 22 0.9	1194
111	40 53 11.9	117 44 16.0	1371	161	40 10 18.9	117 54 28.3	1249	211	39 34 44.5	118 22 24.8	1194
112	40 52 21.1	117 44 20.2	1365	162	40 9 35.9	117 55 15.8	1252	212	39 33 55.6	118 23 20.2	1200
113	40 51 29.6	117 44 25.7	1365	163	40 8 59.3	117 55 56.3	1255	213	39 33 39.6	118 25 2.8	1200
114	40 50 36.5	117 44 57.7	1341	164	40 8 17.3	117 56 39.7	1255	214	39 33 0.7	118 25 38.6	1213
115	40 49 42.0	117 44 31.9	1359	165	40 7 37.5	117 57 29.1	1249	215	39 32 17.3	118 25 39.9	1234
116	40 48 50.4	117 44 4.9	1389	166	40 6 55.9	117 58 15.0	1249	216	39 31 46.2	118 27 10.1	1231
117	40 47 56.1	117 44 3.0	1389	167	40 6 17.4	117 58 59.8	1249	217	39 31 14.9	118 27 56.1	1200
118	40 47 4.5	117 44 7.9	1377	168	40 5 48.9	117 59 20.8	1264	218	39 30 31.8	118 28 25.6	1200
119	40 46 13.1	117 43 58.4	1371	169	40 5 2.7	118 0 18.3	1267	219	39 30 4.5	118 29 17.1	1203
120	40 45 24.1	117 44 28.3	1356	170	40 4 12.6	118 0 38.1	1316	220	39 29 21.5	118 29 46.0	1203
121	40 44 26.9	117 45 18.5	1341	171	40 3 42.8	118 1 39.5	1310	221	39 28 31.8	118 29 57.1	1213
122	40 43 32.3	117 46 10.5	1341	172	40 2 57.7	118 2 29.0	1316	222	39 27 43.2	118 30 1.7	1213
123	40 42 45.7	117 46 14.6	1347	173	40 2 1.2	118 2 47.8	1389	223	39 27 5.2	118 30 33.7	1219
124	40 41 51.3	117 46 7.1	1386	174	40 1 20.4	118 3 7.8	1432	224	39 26 5.4	118 31 24.2	1264
125	40 40 57.8	117 46 29.0	1386	175	40 0 56.9	118 4 41.8	1402	225	39 25 20.3	118 31 38.5	1264
126	40 40 7.8	117 46 58.9	1420	176	40 0 25.3	118 5 21.0	1456	226	39 24 34.7	118 31 58.4	1280
127	40 39 15.0	117 47 11.2	1447	177	39 59 47.3	118 6 45.1	1389	227	39 23 56.4	118 32 29.7	1249
128	40 38 23.2	117 47 21.7	1450	178	39 59 8.0	118 7 49.5	1341	228	39 23 10.8	118 32 58.7	1203
129	40 37 31.1	117 47 14.2	1463	179	39 58 34.7	118 8 15.6	1365	229	39 22 29.3	118 32 57.0	1197
130	40 36 40.4	117 47 7.7	1463	180	39 57 37.7	118 8 44.6	1432	230	39 21 40.5	118 38 6.7	1203*
131	40 35 48.6	117 46 56.6	1475	181	39 56 40.4	118 9 34.3	1356	231	39 21 52.4	118 38 9.7	1213*
132	40 34 53.6	117 46 52.1	1469	182	39 56 5.0	118 9 44.6	1371	232	39 20 42.6	118 37 59.7	1207*
133	40 34 2.5	117 46 34.1	1481	183	39 54 54.1	118 10 9.3	1219	233	39 19 21.2	118 38 14.4	1203*
134	40 33 10.9	117 47 11.5	1524	184	39 54 40.5	118 12 13.7	1203	234	39 18 6.4	118 38 12.2	1197*
135	40 32 10.5	117 47 54.0	1584	185	39 54 24.1	118 13 2.7	1203	235	39 16 43.1	118 38 29.8	1200*
136	40 31 54.3	117 49 42.6	1682	186	39 53 39.8	118 13 22.7	1219	236	39 15 3.4		
137	40 30 50.9	117 51 5.5	1859	187	39 52 51.7	118 13 38.5	1219				
138	40 30 9.4	117 50 48.1	1859	188	39 52 9.0	118 13 56.8	1219				
139	40 29 10.8	117 50 50.8	1615	189	39 51 23.1	118 14 8.1	1219				
140	40 28 15.4	117 51 36.3	1524	190	39 50 37.9	118 14 22.2	1219				
141	40 27 34.3	117 51 59.4	1493	191	39 49 5.5	118 14 33.5	1213				
142	40 26 45.8	117 52 35.1	1438	192	39 48 23.4	118 14 43.2	1210				
143	40 26 3.2	117 53 23.4	1414	193	39 47 37.9	118 15 7.8	1210				
144	40 25 17.2	117 53 37.9	1377	194	39 46 54.8	118 15 33.8	1202				
145	40 24 10.1	117 54 19.7	1310	195	39 46 8.6	118 15 56.5	1205				
146	40 23 22.4	117 53 47.8	1304	196	39 45 25.2	118 16 20.4	1214				
147	40 22 26.8	117 54 0.7	1274	197	39 44 43.8	118 16 46.8	1213				
148	40 21 38.9	117 54 4.0	1267	198	39 44 1.1	118 17 13.2	1203				
149	40 20 34.0	117 54 8.8	1264	199	39 43 18.9	118 17 39.7	1203				
150	40 19 41.8	117 54 11.5	1264	200	39 42 36.7	118 18 5.5	1207				

\* Sites not occupied by the USGS

# Deployment 2

Location number	Latitude (deg,min,sec)	Longitude (deg,min,sec)	Elev (m)	Location number	Latitude (deg,min,sec)	Longitude (deg,min,sec)	Elev (m)	Location number	Latitude (deg,min,sec)	Longitude (deg,min,sec)	Elev (m)
301	40 34 56.7	119 27 25.0	1188	351	40 18 21.5	118 38 50.0	1636	401	40 7 10.5	118 6 50.0	1283
302	40 34 34.4	119 26 4.1	1188	352	40 17 53.0	118 37 59.3	1679	402	40 6 54.5	118 6 18.3	1258
303	40 32 47.1	119 20 15.9	1280	353	40 17 51.1	118 37 4.6	1615	403	40 6 46.8	118 5 49.2	1246
304	40 32 30.3	119 19 12.5	1353	354	40 17 5.9	118 34 28.9	1533	404	40 6 40.8	118 5 12.2	1240
305	40 32 9.0	119 18 5.0	1463	355	40 16 29.7	118 34 4.6	1475	405	40 6 34.3	118 4 35.3	1234
306	40 31 52.0	119 17 16.2	1584	356	40 16 35.9	118 33 41.7	1490	406	40 6 29.0	118 3 56.0	1234
307	40 31 27.9	119 16 26.9	1767	357	40 16 38.7	118 32 50.5	1469	407	40 6 22.7	118 3 19.7	1234
308	40 31 14.8	119 15 32.0	1828	358	40 16 16.3	118 31 30.4	1402	408	40 6 17.1	118 2 43.4	1234
309	40 30 47.5	119 14 49.6	1624	359	40 16 12.6	118 30 46.1	1356	409	40 6 11.5	118 2 7.2	1234
310	40 30 32.5	119 14 1.1	1548	360	40 15 47.5	118 30 24.4	1298	410	40 6 5.4	118 1 30.8	1237
311	40 30 8.4	119 12 43.4	1493	361	40 15 41.8	118 29 37.4	1274	411	40 6 0.5	118 0 55.3	1240
312	40 29 30.6	119 12 11.4	1469	362	40 15 44.5	118 29 17.3	1249	412	40 5 54.1	118 0 18.6	1246
313	40 29 19.5	119 11 15.9	1447	363	40 15 31.7	118 28 40.9	1231				
314	40 29 2.6	119 10 18.4	1432	364	40 15 33.8	118 28 26.8	1225				
315	40 28 49.6	119 9 23.1	1411	365	40 15 16.9	118 27 41.7	1222				
316	40 28 36.5	119 8 27.6	1402	366	40 15 16.6	118 26 59.4	1222				
317	40 28 20.4	119 7 21.6	1392	367	40 15 16.8	118 26 18.2	1222				
318	40 28 3.0	119 6 19.4	1383	368	40 15 17.3	118 25 38.6	1222				
319	40 27 57.5	119 5 28.7	1380	369	40 15 19.8	118 24 16.1	1225				
320	40 27 51.5	119 4 34.1	1379	370	40 15 13.5	118 23 46.4	1231				
321	40 27 45.3	119 3 36.7	1374	371	40 14 56.0	118 23 32.4	1243				
322	40 27 38.4	119 2 36.0	1371	372	40 14 34.0	118 23 2.0	1243				
323	40 27 14.5	119 1 51.7	1365	373	40 14 31.2	118 22 21.4	1255				
324	40 26 47.8	119 1 1.1	1356	374	40 14 25.0	118 21 29.0	1298				
325	40 26 21.4	119 0 10.3	1322	375	40 14 12.6	118 20 55.2	1328				
326	40 25 49.0	118 59 26.4	1356	376	40 13 58.9	118 20 17.6	1371				
327	40 25 17.3	118 58 40.3	1365	377	40 13 43.1	118 19 46.6	1402				
328	40 24 55.3	118 57 52.3	1350	378	40 13 32.4	118 19 14.5	1463				
329	40 24 53.0	118 56 49.4	1322	379	40 13 22.3	118 18 30.6	1463				
330	40 24 59.1	118 55 54.3	1301	380	40 13 8.5	118 17 49.7	1493				
331	40 24 42.4	118 54 59.9	1274	381	40 12 52.0	118 17 26.7	1524				
332	40 24 32.5	118 54 37.0	1267	382	40 12 35.5	118 16 59.9	1524				
333	40 24 25.1	118 54 0.7	1274	383	40 12 25.4	118 16 24.0	1554				
334	40 24 2.2	118 53 18.7	1267	384	40 12 0.3	118 15 54.4	1524				
335	40 23 39.5	118 52 2.7	1325	385	40 11 54.0	118 15 19.5	1463				
336	40 23 45.0	118 50 55.3	1429	386	40 11 44.4	118 14 44.8	1493				
337	40 23 9.6	118 50 15.3	1648	387	40 11 33.6	118 14 9.6	1402				
338	40 22 26.0	118 49 30.3	1371	388	40 11 18.4	118 13 36.8	1374				
339	40 22 12.2	118 48 16.6	1286	389	40 11 9.7	118 12 47.5	1399				
340	40 21 42.5	118 47 11.5	1307	390	40 11 4.7	118 12 13.2	1444				
341	40 21 1.7	118 47 2.4	1316	391	40 10 55.6	118 11 40.1	1499				
342	40 20 23.6	118 47 11.0	1319	392	40 10 37.8	118 11 6.3	1536				
343	40 20 2.9	118 46 8.4	1386	393	40 10 2.0	118 10 50.4	1615				
344	40 20 38.1	118 44 7.0	1423	394	40 9 33.8	118 10 24.6	1536				
345	40 20 24.0	118 43 21.0	1432	395	40 9 9.5	118 9 50.1	1463				
346	40 20 8.9	118 42 21.6	1524	396	40 8 52.4	118 9 4.0	1402				
347	40 19 45.1	118 41 33.6	1527	397	40 8 31.6	118 8 31.9	1365				
348	40 19 11.1	118 40 20.1	1509	398	40 8 17.5	118 8 3.1	1344				
349	40 18 59.3	118 39 36.6	1600	399	40 7 58.1	118 7 21.6	1306				
350	40 18 10.3	118 38 56.5	1603	400	40 7 26.1						

# Deployment 3

Location number	Latitude (deg,min,sec)	Longitude (deg,min,sec)	Elev (m)	Location number	Latitude (deg,min,sec)	Longitude (deg,min,sec)	Elev (m)
501	40 5 41.3	117 59 17.1	1264	551	39 52 15.0	117 30 17.5	1478
502	40 5 24.4	117 58 17.6	1295	552	39 51 42.8	117 30 0.4	1493
503	40 5 10.1	117 57 4.6	1341	553	39 51 5.9	117 29 19.3	1591
504	40 5 17.0	117 55 55.7	1402	554	39 50 54.3	117 28 18.7	1554
505	40 5 15.2	117 55 12.3	1450	555	39 50 56.8	117 27 27.7	1615
506	40 4 18.0	117 54 23.1	1554	556	39 50 36.7	117 26 55.8	1615
507	40 3 55.8	117 53 32.2	1615	557	39 50 20.1	117 25 58.5	1609
508	40 4 43.7	117 52 33.0	1584	558	39 50 0.1	117 25 9.3	1591
509	40 4 39.5	117 51 36.3	1706	559	39 49 42.6	117 24 12.4	1597
510	40 4 23.3	117 50 49.5	1783	560	39 49 25.1	117 23 21.2	1601
511	40 4 26.1	117 50 7.5	1859	561	39 49 3.3	117 22 37.9	1612
512	40 4 27.8	117 49 18.4	1859	562	39 48 19.6	117 21 58.1	1615
513	40 4 40.0	117 48 39.0	1584	563	39 47 43.8	117 21 33.6	1639
514	40 4 33.2	117 47 57.7	1264	564	39 47 24.2	117 20 39.9	1658
515	40 4 5.0	117 47 34.8	1146	565	39 47 19.5	117 19 42.2	1682
516	40 3 11.1	117 47 23.8	1078	566	39 47 11.7	117 18 22.2	1752
517	40 2 49.5	117 47 7.1	1069	567	39 46 51.4	117 16 49.0	1874
518	40 2 24.3	117 46 42.8	1071	568	39 46 17.4	117 15 49.2	1700
519	40 2 1.1	117 46 20.7	1069	569	39 45 54.0	117 14 47.4	2072
520	40 1 33.7	117 45 59.3	1071	570	39 45 23.3	117 14 13.7	1920
521	40 1 11.2	117 45 34.2	1071	571	39 45 13.1	117 12 35.9	1773
522	40 0 24.6	117 45 9.7	1071	572	39 44 48.2	117 11 33.6	1728
523	40 0 48.6	117 44 43.7	1071	573	39 44 12.1	117 11 0.2	1667
524	40 0 2.0	117 44 23.1	1071	574	39 43 37.5	117 10 37.4	1673
525	39 59 39.0	117 43 44.6	1078	575	39 42 59.6	117 10 5.1	1694
526	39 59 10.2	117 43 30.9	1085	576	39 42 44.1	117 9 25.4	1709
527	39 58 45.0	117 43 11.3	1097	577	39 42 25.8	117 8 35.4	1733
528	39 57 37.5	117 42 6.2	1115	578	39 42 6.8	117 7 26.9	1804
529	39 57 19.4	117 42 33.5	1127	579	39 41 53.9	117 6 29.4	1828
530	39 57 5.9	117 42 3.0	1133	580	39 41 35.5	117 5 29.2	1862
531	39 56 20.9	117 41 14.0	1158	581	39 41 18.5	117 4 32.2	1898
532	39 56 9.0	117 40 48.5	1158	582	39 40 45.7	117 3 47.8	1920
533	39 55 56.4	117 40 21.6	1170	583	39 40 27.9	117 2 59.2	1944
534	39 55 43.1	117 39 55.6	1176	584	39 40 13.1	117 2 7.2	1981
535	39 55 40.1	117 39 5.8	1219	585	39 39 47.3	117 1 3.1	2039
536	39 55 31.2	117 38 40.5	1219	586	39 39 12.2	117 0 30.7	2075
537	39 55 19.9	117 38 6.5	1219	587	39 39 15.5	116 59 55.1	2133
538	39 55 2.5	117 37 33.0	1231	588	39 38 35.5	116 59 7.4	2438
539	39 54 53.8	117 36 55.1	1234	589	39 38 21.3	116 57 39.2	2560
540	39 54 38.8	117 36 16.7	1249	590	39 37 26.4	116 57 13.1	2499
541	39 54 14.7	117 35 47.9	1280	591	39 36 43.2	116 56 20.5	2438
542	39 54 1.7	117 35 24.2	1280	592	39 36 40.2	116 55 26.9	2255
543	39 53 53.9	117 34 48.3	1295	593	39 36 29.5	116 54 28.9	2090
544	39 53 44.3	117 34 10.9	1304	594	39 36 23.8	116 54 7.5	2103
545	39 53 30.8	117 33 37.3	1328	595	39 35 54.4	116 53 43.8	2011
546	39 53 17.1	117 33 4.8	1341	596	39 35 34.1	116 52 57.3	1981
547	39 52 52.1	117 32 35.0	1356	597	39 35 5.5	116 52 0.0	1956
548	39 52 37.9	117 32 5.3	1386	598	39 35 31.3	116 50 37.1	2026
549	39 52 34.5	117 31 32.8	1402	599	39 35 8.8	116 49 35.8	2005
550	39 52 34.5	117 30 43.2	1463	600	39 34 13.0	116 49 13.0	2042

\* Sites not occupied by the USGS

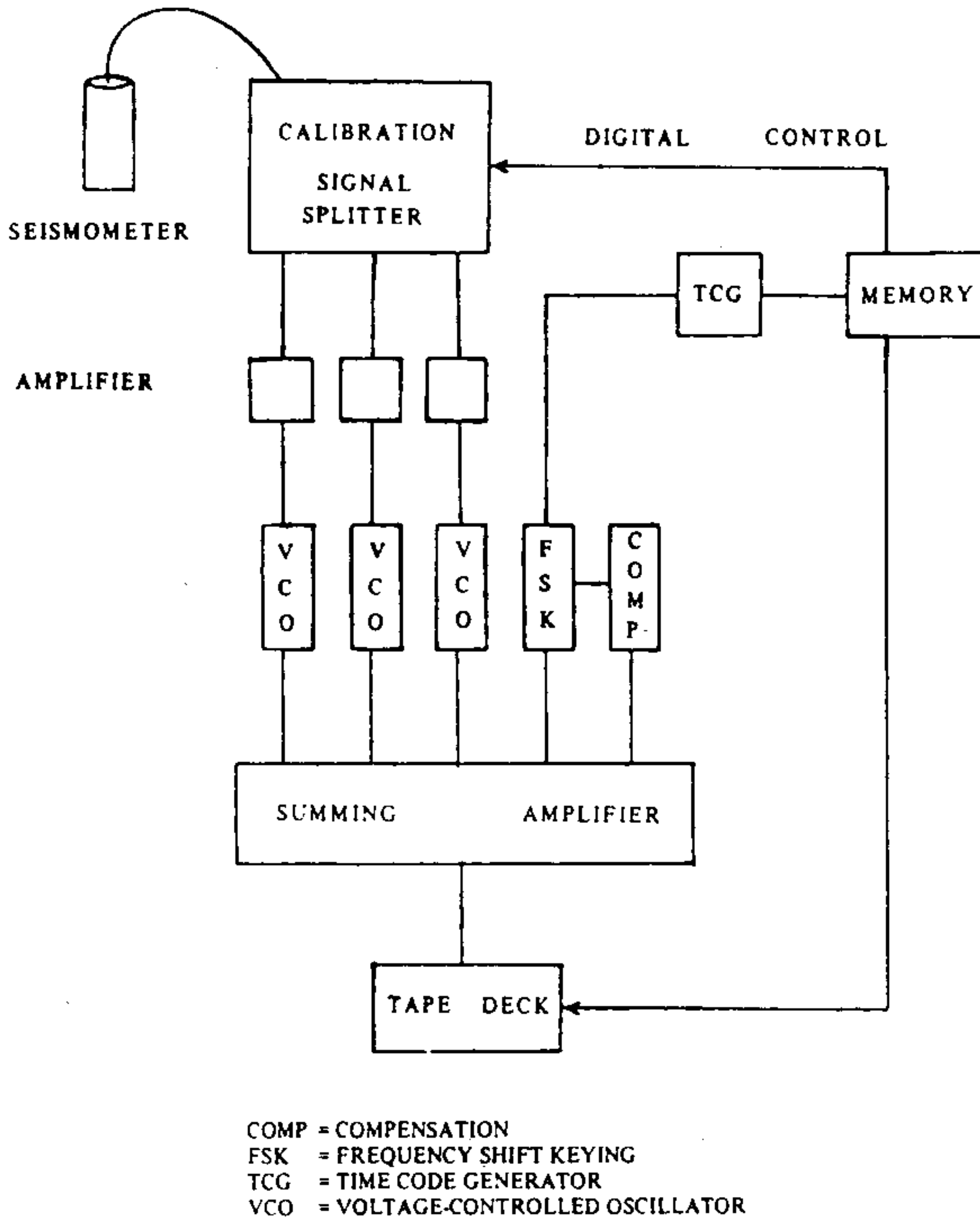

Figure 2. Schematic diagram of the seismic cassette recorders.

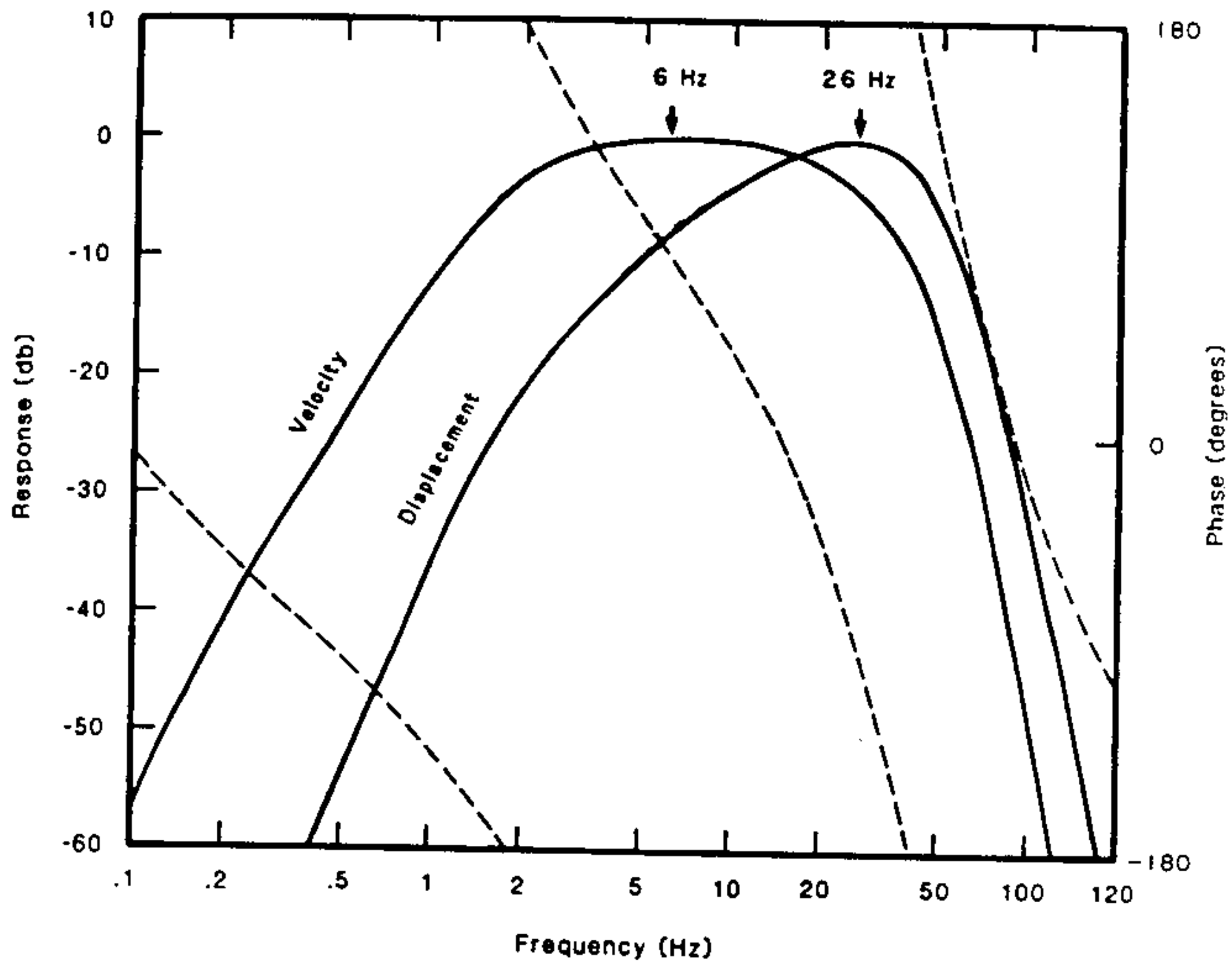
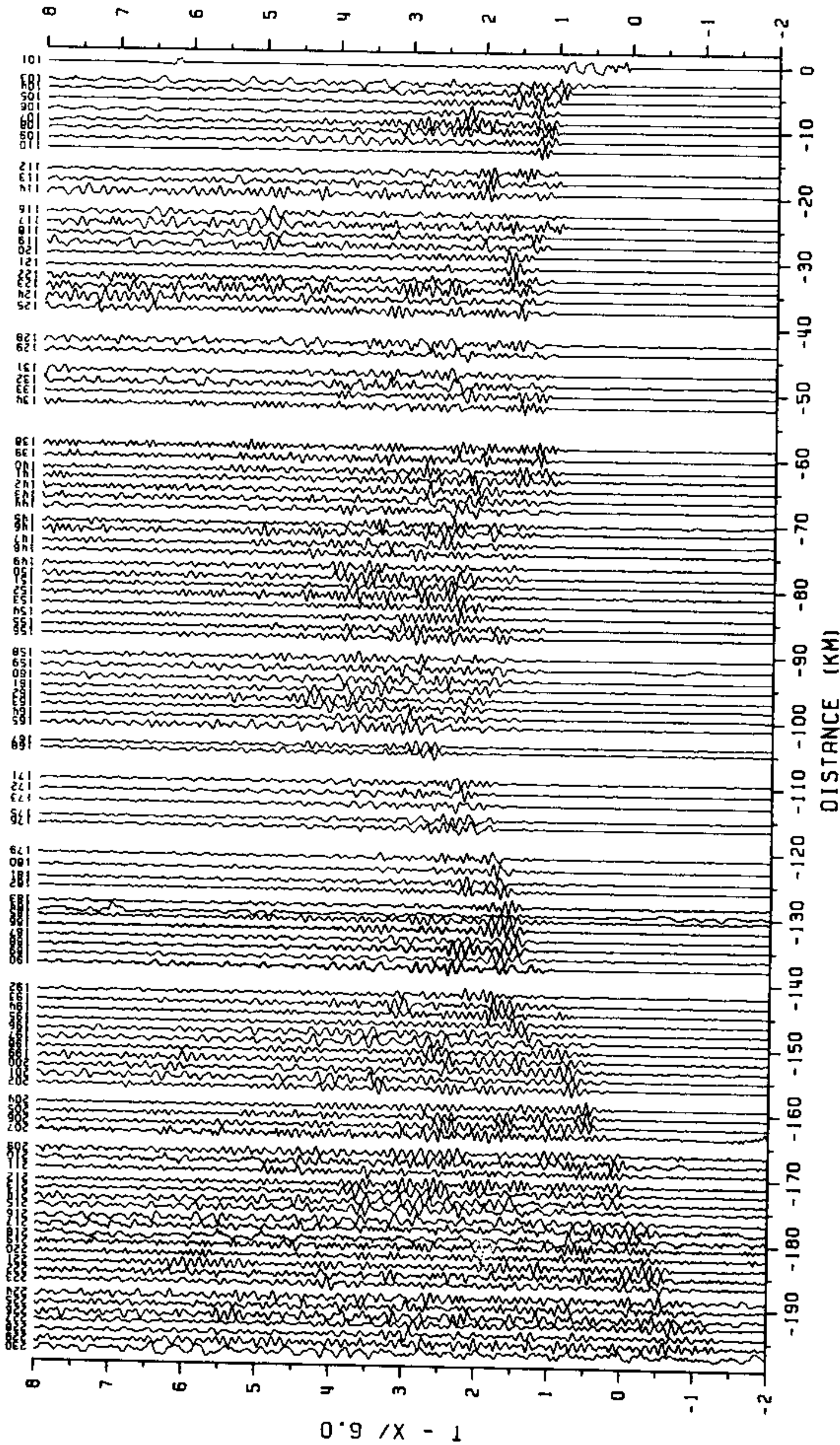
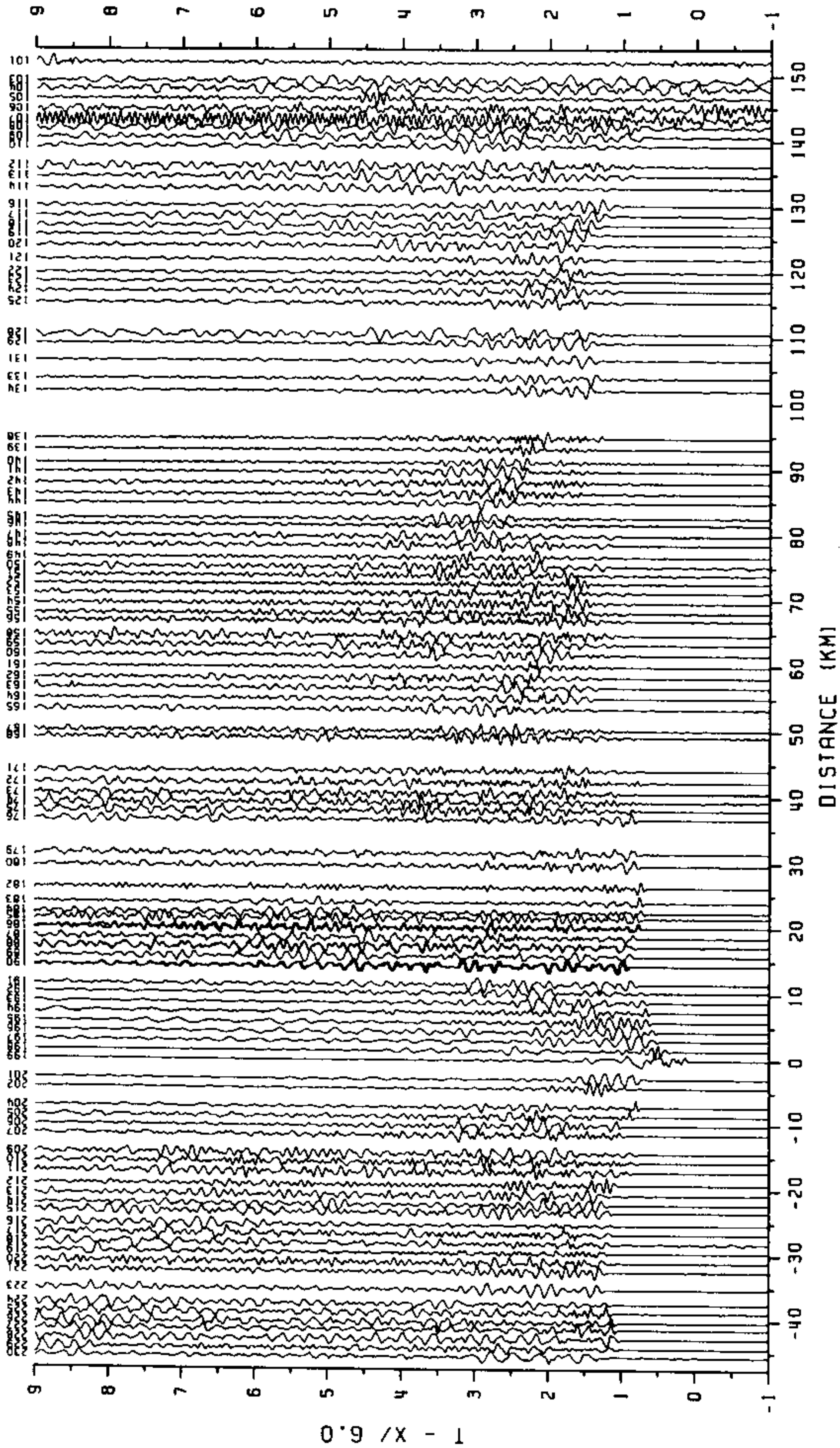

Figure 3. Theoretical transfer-function curves for the USGS seismic cassette recorders. Solid line: displacement and velocity normalized amplitude; dashed line: phase (displacement). Maximum velocity response is at 6 Hz; maximum displacement response is at 26 Hz (after Dawson and Stauber, 1986).



Shot 1, Shotpoint 8

Figure 4: Record Section from Deployment 1



Shot 2, Shotpoint 10

Figure 5: Record Section from Deployment 1

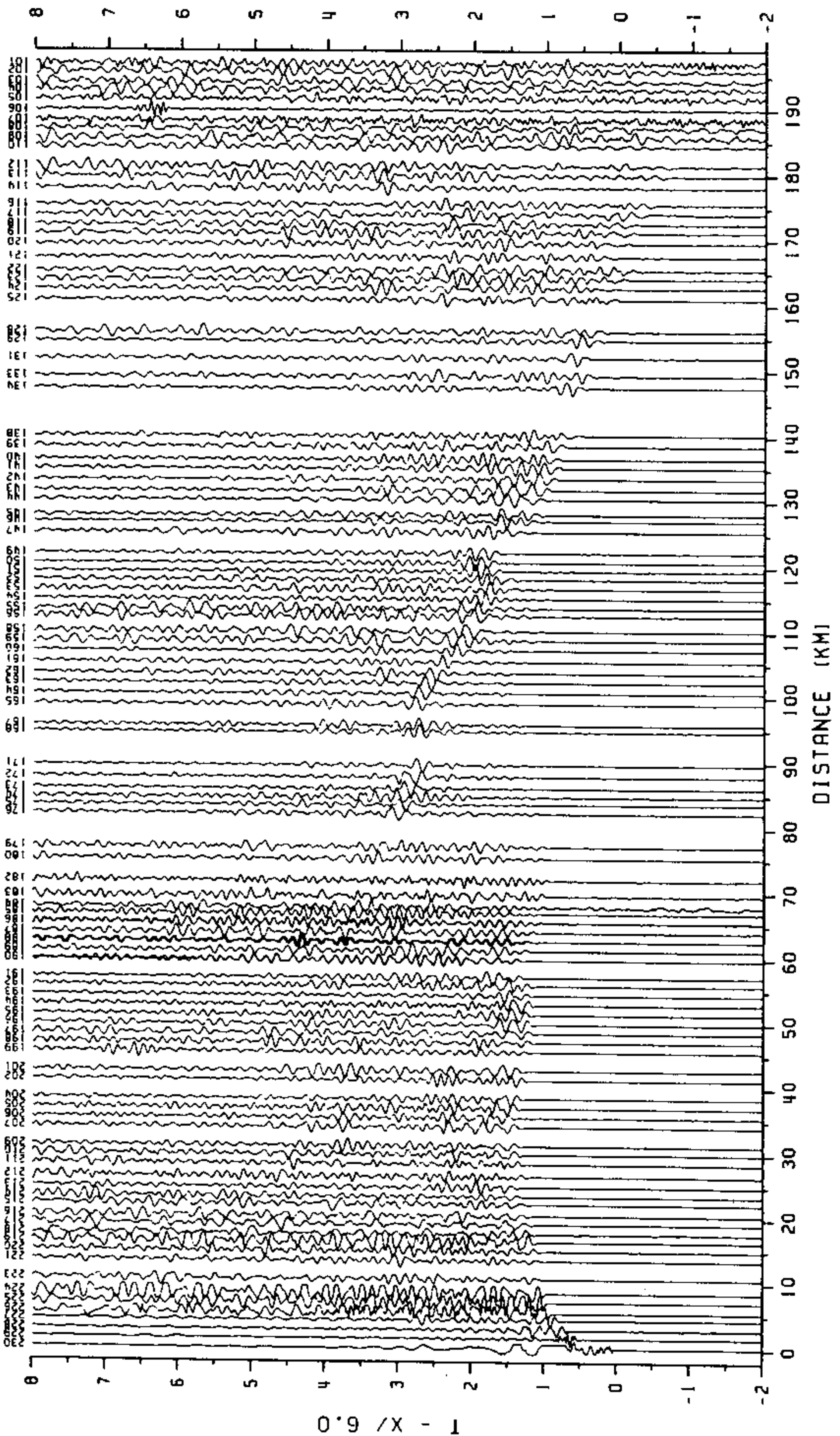

Shot 3, Shotpoint 11

Figure 6: Record Section from Deployment 1

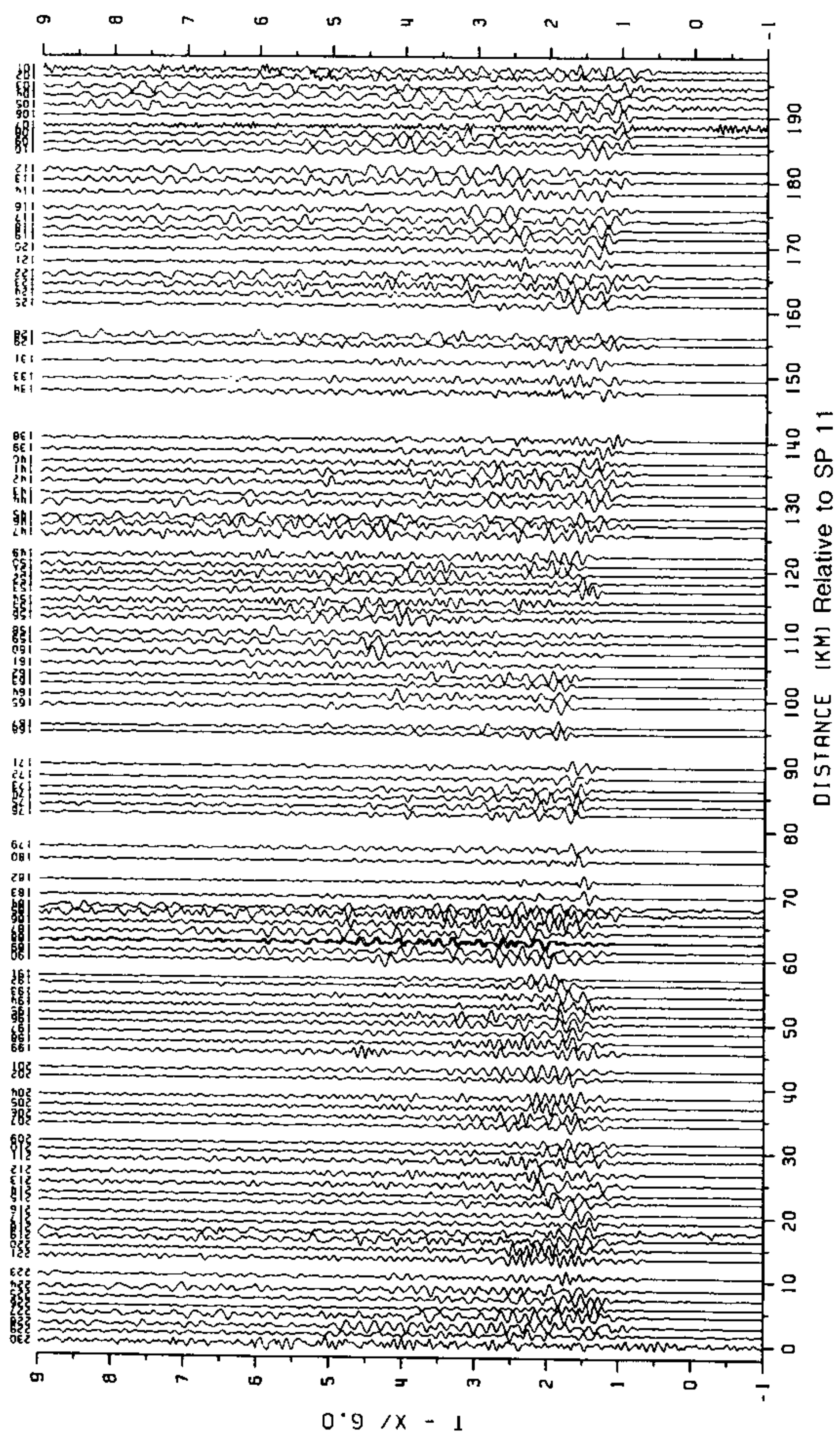

Shot 4, Shotpoint 1 (Fan Shot)

Figure 7: Record Section from Deployment 1

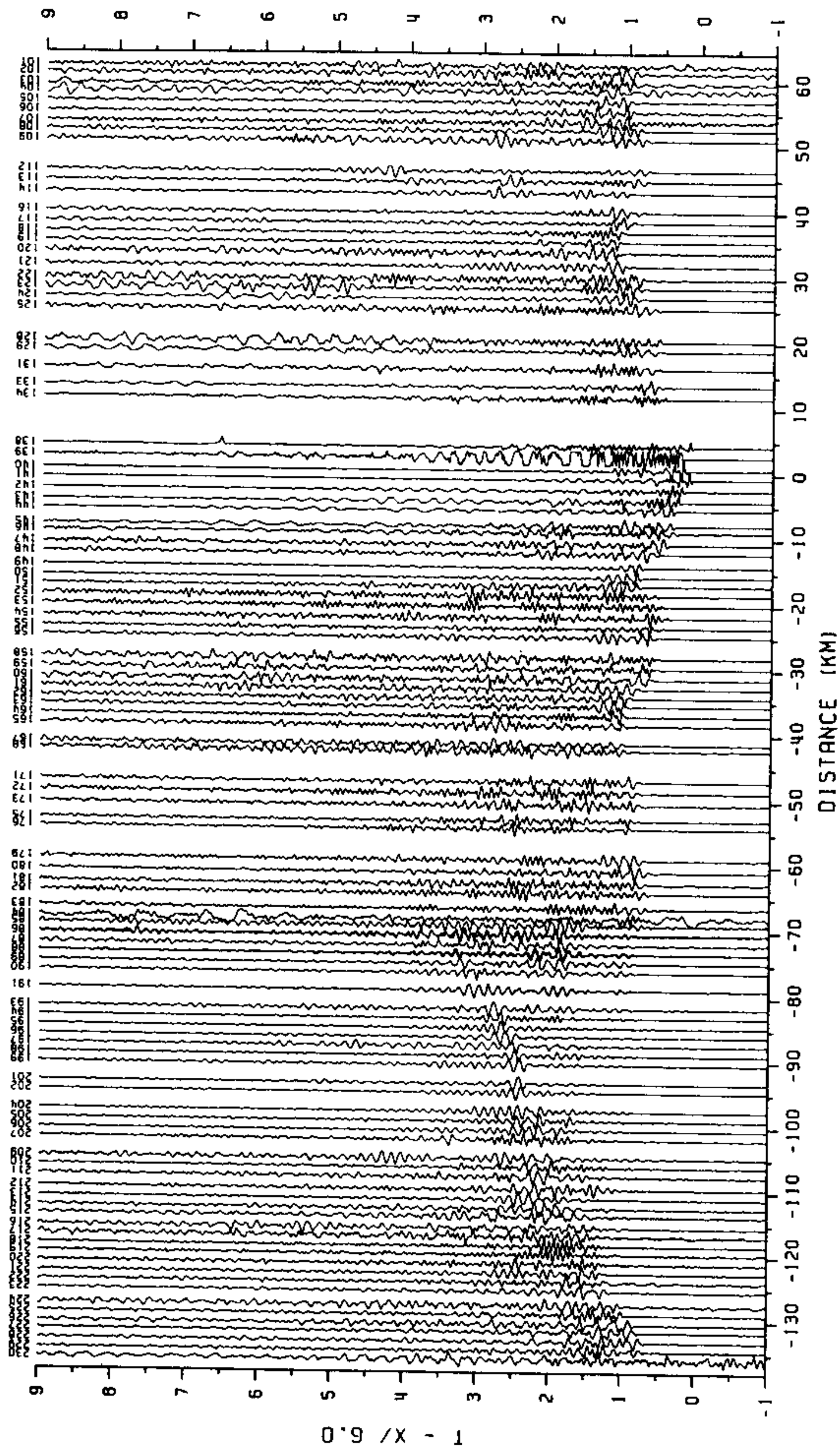

Shot 5, Shotpoint 9

Figure 8: Record Section from Deployment 1

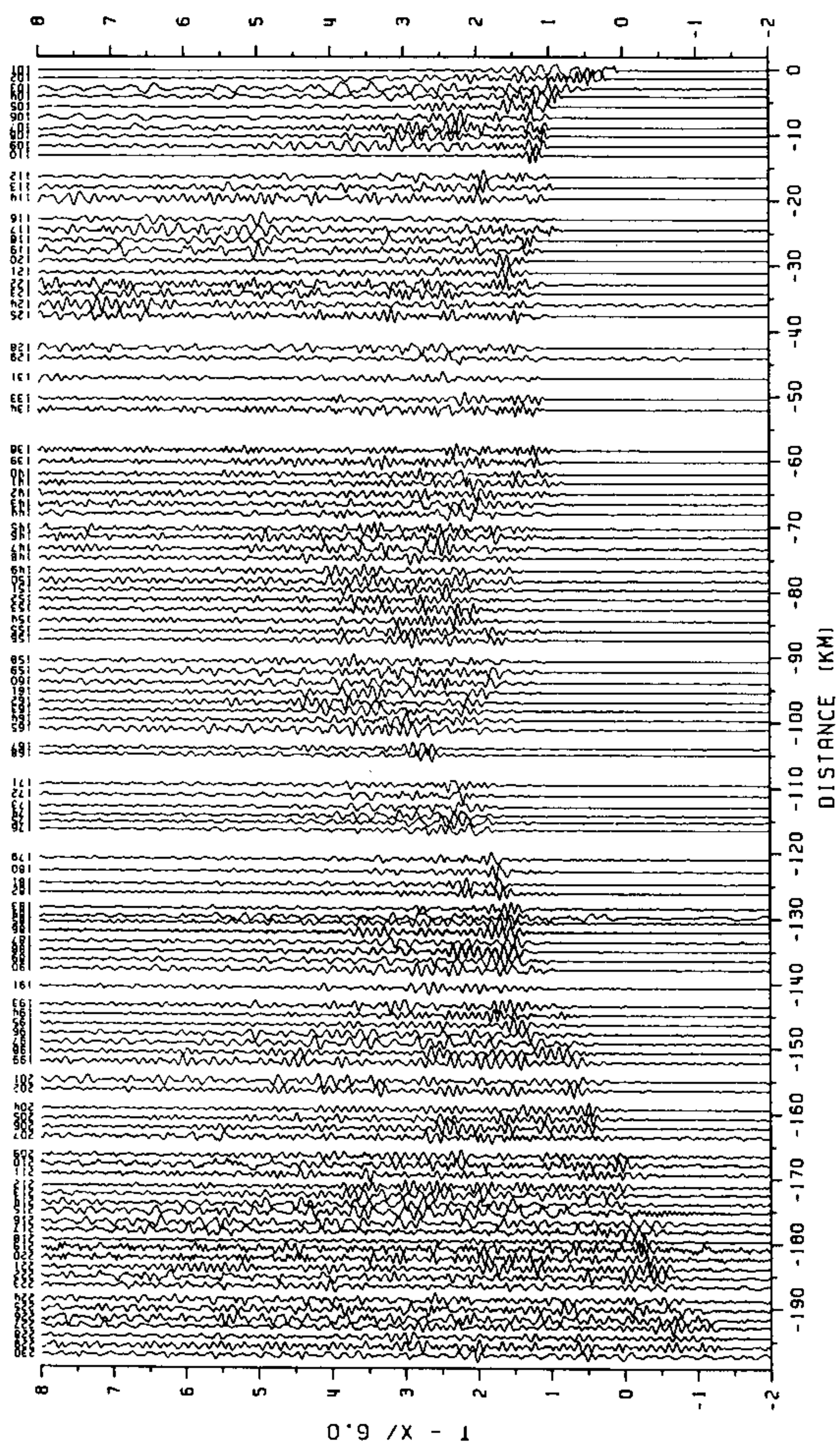

Shot 6, Shotpoint 8

Figure 9: Record Section from Deployment 1

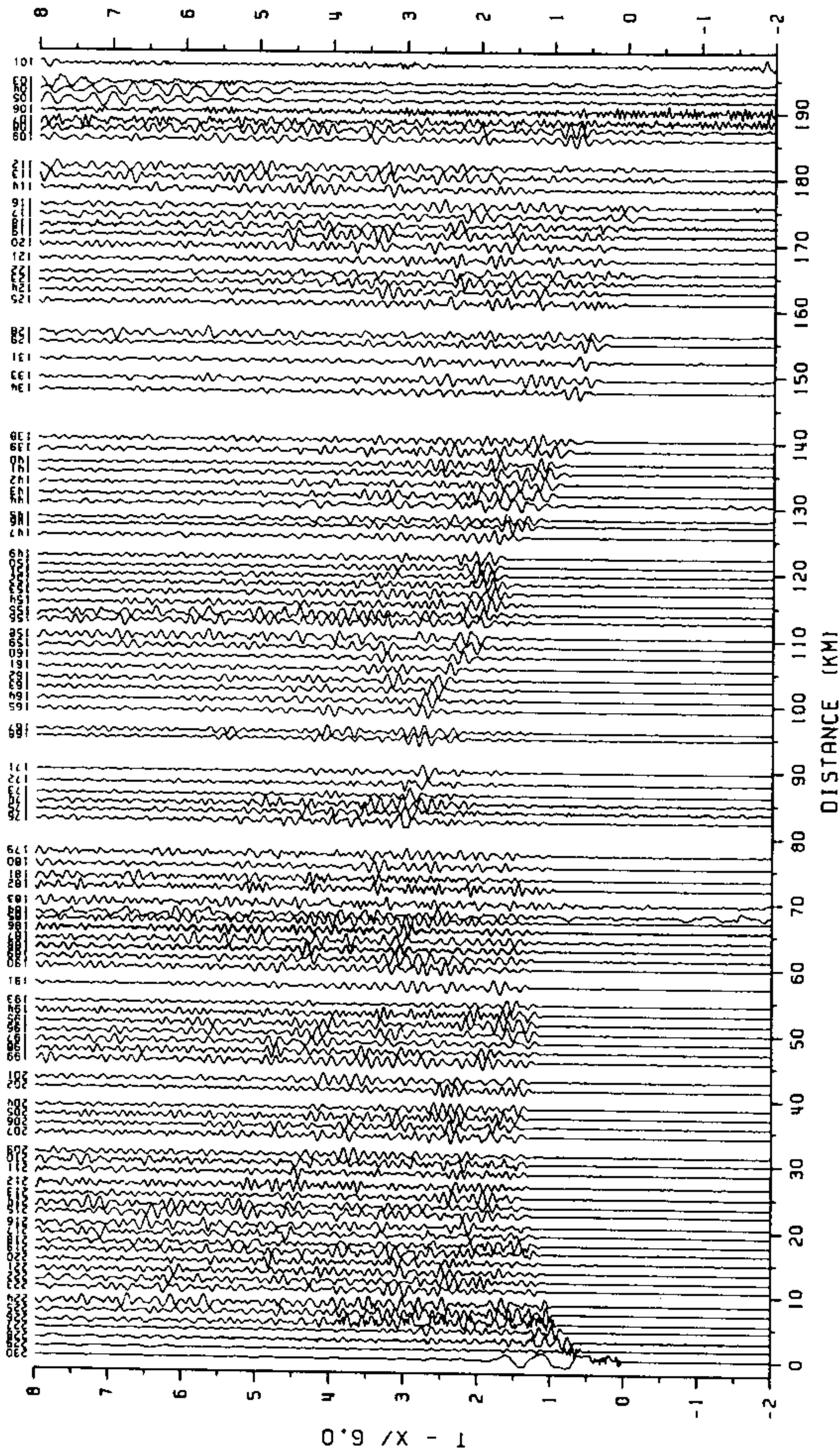

Shot 7, Shotpoint 11

Figure 10: Record Section from Deployment 1